

LOGSTOR *SX* Joint system



**Shrinkable jointing system for
pre-insulated pipe systems**

● distributing energy efficiency

LOGSTOR

LOGSTOR SXJoint system – for linking pre-insulated pipes

- One single system for all joints
- The unique molecular structure of cross-linked polyethylene keeps the casing joint firmly in place
- Remains completely sealed throughout its service life
- Can be shrunk in two dimensions, making it ideal for reduction joints
- Makes pre-insulated pipe systems more reliable and reduces long-term operating costs
- Makes it easy for you to route piping in the most straightforward, cost-effective way
- Fewer joints are needed, providing you with 10–15% reductions on installation costs
- Fewer joints mean less welding, with less likelihood of problems arising
- Installation requires less manpower and simple tools
- You can easily establish new branches on existing pipe systems, without interrupting operations
- Complies with – and considerably exceeds – EN489 standard requirements

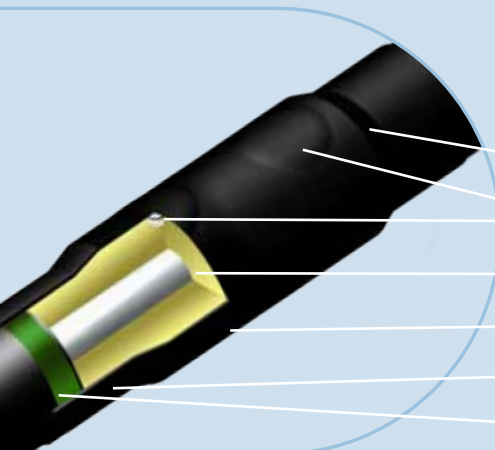

- Cross-linked polyethylene (PEX)
- Double-sealed foaming/air vent holes
- Polyurethane (PUR) insulating foam
- Non-shrinkable centre section of the casing joint
- Shrinkable ends of the casing joint
- Mastic sealant

Like all other LOGSTOR joining systems, the SXJoint is designed to provide maximum safety and durability, and at the same time keep heat loss to the absolute minimum.

The SX casing joint is made of cross-linked polyethylene (PEX) and designed to take full advantage of the special properties of this extremely resilient and durable material, and therefore remains sealed throughout its entire service life.

The LOGSTOR SXJoint system is a versatile, resilient and reliable shrinkable joining system. It includes everything you need for easy, cost-effective jointing of pre-insulated pipe sections – even in locations where these are exposed to exceptional sub-soil conditions.

Fewer, simpler joints involve fewer components and simpler logistics, saving on time and money.

They are quick to install and require less manpower, while the easy, straightforward SX jointing process virtually eliminates any subsequent in-service issues.

This means you can easily reduce installation costs by as much as 10–15% and pipe length costs by 3–5%.

One joint only with LOGSTOR SXJoint system



Pre-fabricated branch requires three joints

Where to use

The SXJoint system is ideal for pre-insulated pipes that have to withstand mechanical, thermal and chemical stresses.

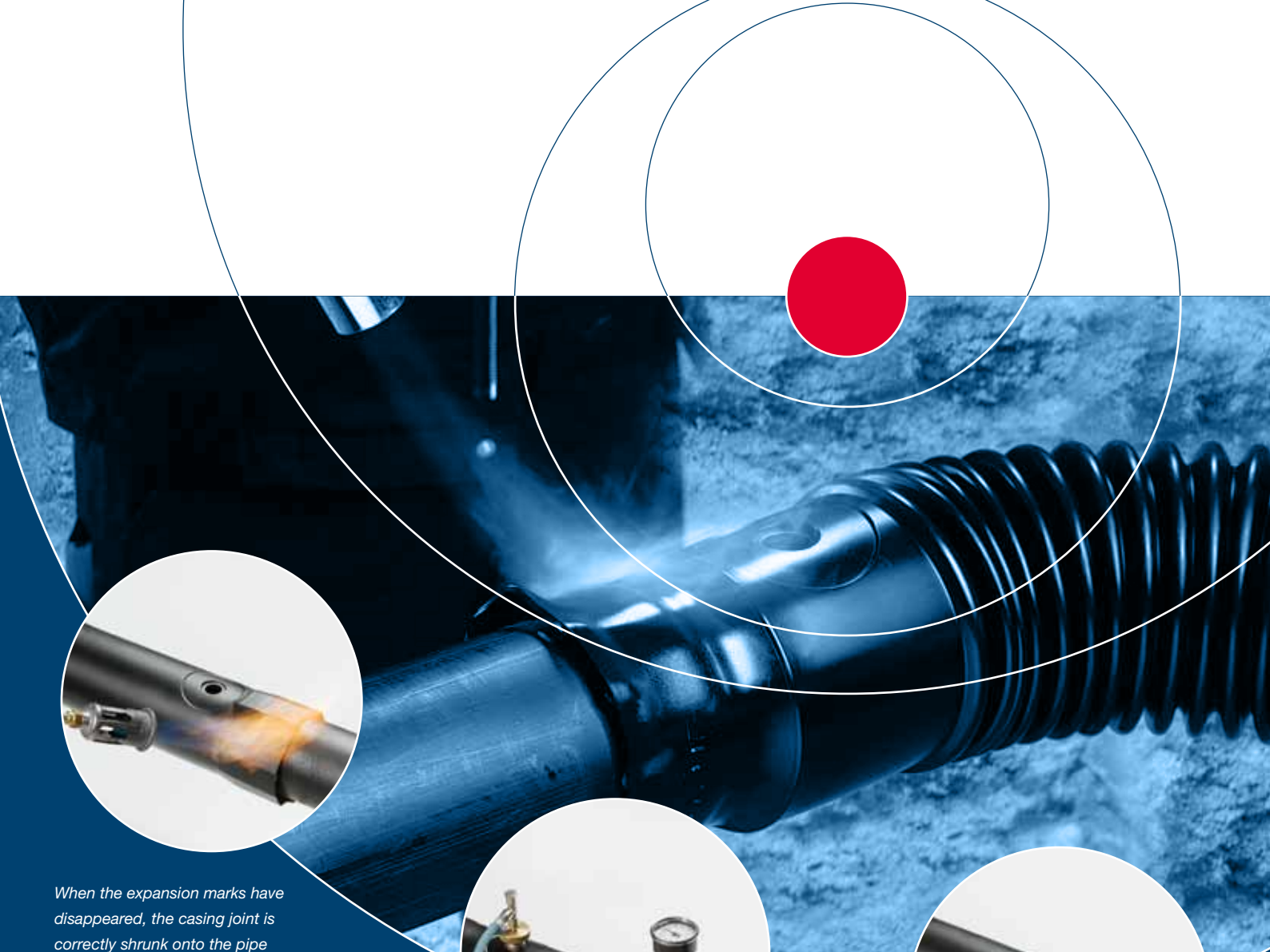

When the expansion marks have disappeared, the casing joint is correctly shrunk onto the pipe casing

Simple to install, easy to inspect

Installation is an easy, straightforward process for which only simple tools are needed. Installers with a basic training can therefore do the job easily.

The four simple visual inspection steps shown above help you confirm that each procedure has been carried out correctly.



Pressure testing for leaks prior to foaming



Monitoring that foaming has been done correctly

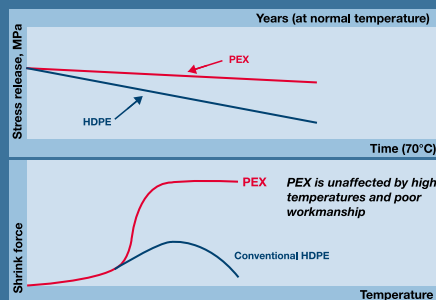

The PEX advantage

The unique molecular structure of cross-linked polyethylene (PEX) means that its properties include an exceptionally strong shrink force.

When heated, this material can be expanded to any required shape, and it retains this shape when subsequently cooled. If PEX is then reheated to temperatures above 120°C, it always shrinks back to its original shape.

Unlike high-density polyethylene (HDPE), PEX is unaffected by any over-heating during installation and retains its shrink force, with no creep deformation, throughout its service life.

The special properties of PEX are the key to the shrinkable LOGSTOR SXJoint system.

Designed for the job

The SXJoint system is one of three different LOGSTOR casing joint technologies designed to interface perfectly with LOGSTOR pre-insulated pipe systems. The aim is to ensure consistent heat retention and complete reliability for the entire service life of the system.



The green pigment disappears when the patch for double sealing has been heated to the correct temperature

Three types of joints

The LOGSTOR SXJoint system features the three different types of casing joints needed to connect straight pipe runs, and to establish bends and branches. One type of casing joint (SXB) enables you to establish bends of any required angle.

These are delivered sealed in plastic as protection against moisture and dirt until the casing joint is actually installed.

How it works

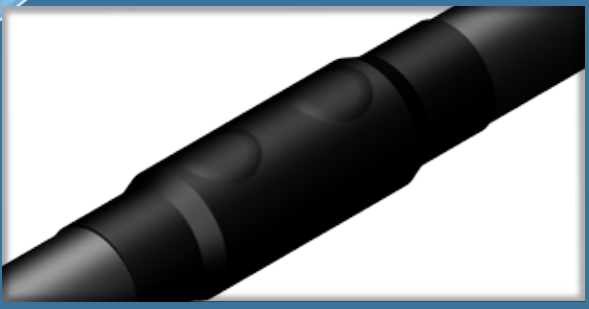

LOGSTOR SXJoints are made of extruded, cross-linked polyethylene (PEX), with a non-shrinkable centre section and shrinkable ends. The insides of these shrinkable ends are coated with a special mastic sealant that makes sure they remain in position and that the joint is completely sealed throughout the service life of the pipe.



Each SX joint is placed on the pre-insulated pipe before the service pipe sections are welded together. The ends of the casing joint are then shrunk into place around the outer casing by heating them to above 120°C, using a propane torch.

Next, the joint is leak-tested and insulated using LOGSTOR FoamPack. It contains the components that provide the exact quantity of polyurethane (PUR) foam needed for filling the casing joints for each particular diameter. The foaming/air vent holes are double-sealed once foaming is finished.



The PUR insulation in the bulkier centre section is bonded to both the casing and the service pipe, and is thus effectively “wedged” in place. This helps make sure the casing joint remains in position, regardless of how much the pre-insulated pipe system parts move, expand or contract.

If you would like more details and/or technical specifications for the LOGSTOR SXJoint system, go to www.logstor.com

Components

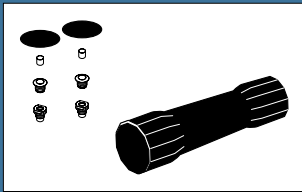

SX - straight joint

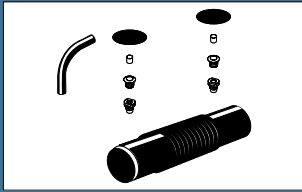

SXB - bend joint,
covers all angles

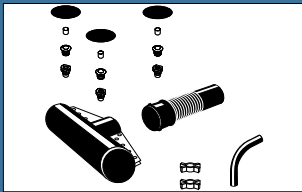

SXT - branch joint,
for straight and
parallel branches

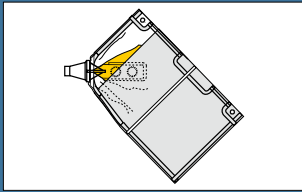

FoamPack

Technical data - LOGSTOR SXJoint system

| Material | | | |
|---------------------------|--|-----------------------------------|--------------|
| Casing joints | | Cross-linked polyethylene (PEX) | |
| Flanges and bolts for SXT | | High grade stainless steel | |
| | | Range of casing dimension, (Ø mm) | |
| SX - straight joints* | | | |
| Single pipe | | 90-450 | |
| TwinPipe | | 125-450 | |
| SXB - bend joints* | | | |
| Single pipe | | 90-315 | |
| TwinPipe | | 125-315 | |
| SXT - branch joints | | Main pipe | Branch pipe* |
| Single pipe | | 90-315 | 77-200 |
| TwinPipe | | 125-315 | 125-200 |

*Shrinkable over two dimensions.

Documented standards

The LOGSTOR SXJoint system complies with the EN489 standard for directly buried pre-insulated pipe systems. In fact, it has been successfully tested under loads 10 times greater than EN489 requirements.

Quality-managed production and installation

LOGSTOR proactively addresses both quality and environmental concerns from component manufacture to finished installation. ISO 9001 and ISO 14001 standards are the basis for the manufacture of all LOGSTOR pipes and components.

We provide your staff, contractors, consultant engineers and supervisors with detailed, hands-on training in how best to use LOGSTOR SXJoint system and its components at the LOGSTOR Training Centre or on site.

● distributing energy efficiency

LOGSTOR A/S
Danmarksvej 11 · DK-9670 Løgstør
Tel. +45 9966 1000 · Fax +45 9966 1180
logstor@logstor.com · www.logstor.com

LOGSTOR